

Features

- * Adjustable wattages: 60%/ 80%/ 100%
- * Adjustable CCT: 4500K/ 5000K/ 5700K
- * Suitable for replacing 100~500W metal halide/ HPS
- * Supports 100~277V/ 277~480V voltage input
- * Transparent PC Cover, extruded aluminum heat sink for better heat dissipation performance
- * Provides a 120-degree beam angle, designed for horizontal lighting applications
- * Equipped with 1 or 2 fans for active cooling
- * Available in 60~120W power range
- * 6K High voltage surge test passed
- * Offers a lifespan of 50,000 hours
- * E26/ E27/ E39/ E40 Mogul screw base
- * SMD2835, 150lm/w LED chips
- * Emits no UV or IR radiation
- * No magnetic disturbance driver
- * 5 years warranty



| CCT Adjustable | | Power Adjustable | | | |
|----------------|-------|------------------|------------|-------------|-------------|
| WW | 4500K | 60W | 80W | 100W | 120W |
| NW | 5000K | L | M | H | |
| CW | 5700K | 36W | 48W | 60W | 72W |
| | | 48W | 64W | 80W | 96W |
| | | 60W | 80W | 100W | 120W |



60W/ 80W

100W/ 120W



DIMENSIONS

| Series | Lumens | LED Type | Base | Electrical Data | Color Temperature | Color Rendering Index |
|-----------------------------|----------|---------------------------|------|---|-------------------------|-----------------------|
| NG-HCL-60W NG-HCL-60WH | 9000 Lm | 336 PCS SMD 2835 Chips | E26 | Input Voltage AC100-277V/ AC277-480V | 4500K 5000K 5700K | Ra≥80 |
| NG-HCL-80W NG-HCL-80WH | 12000 Lm | | E27 | | | |
| NG-HCL-100W NG-HCL-100WH | 15000 Lm | 504 PCS SMD 2835 Chips | E39 | 50/60Hz | | |
| NG-HCL-120W NG-HCL-120WH | 18000 Lm | | E40 | Power Factor(>)>90 | | |

DIMENSIONS

60W/ 80W

Weight: 500g/ 1.10 lbs

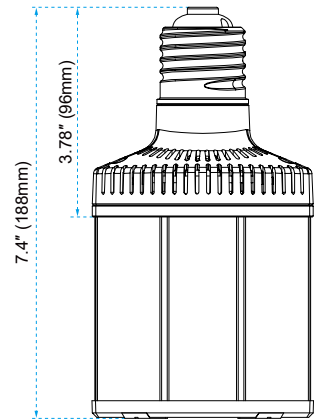
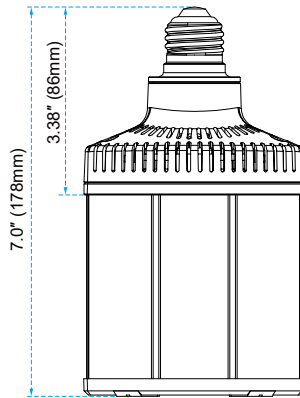
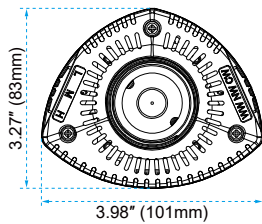

E26

E39

100W/ 120W

Weight: 750g/ 1.65 lbs

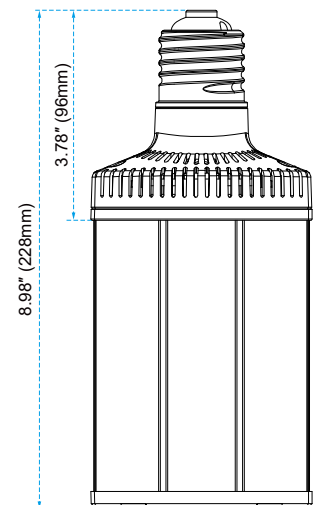
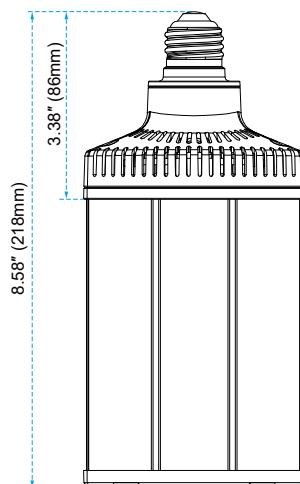
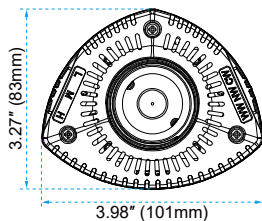

INSTALLATION INSTRUCTIONS

1. Remove old ballast or disconnect from existing lamp holder.
Remove and dispose of ballast in correct manner.
Shown as Figure 1.(North America 100-277 VAC)

Fig1

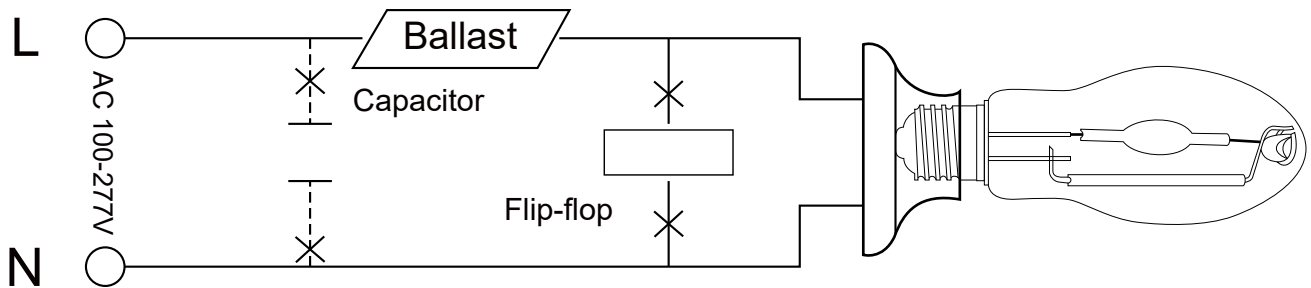

2. Reconnect directly to the existing lamp holder. Shown as Figure 2.
(North America 100-277VAC)

Fig2

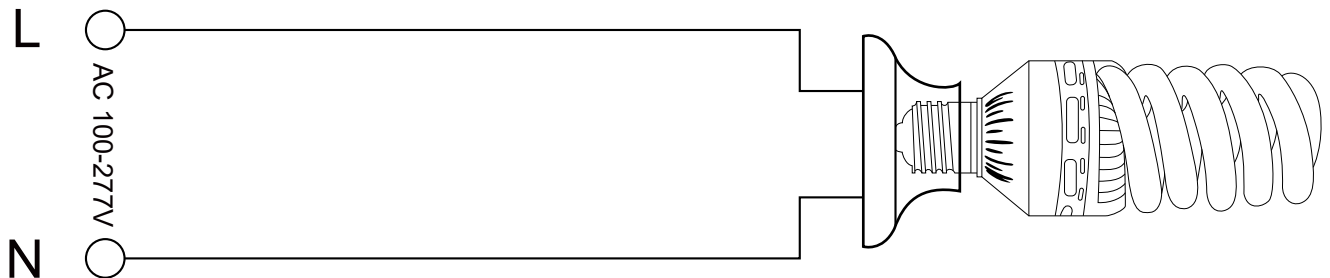

3. Install New LED Replacement lamp. Shown as Figure 3. Please make sure the old fitting is correctly earth. (North America 100-277VAC)

Fig3

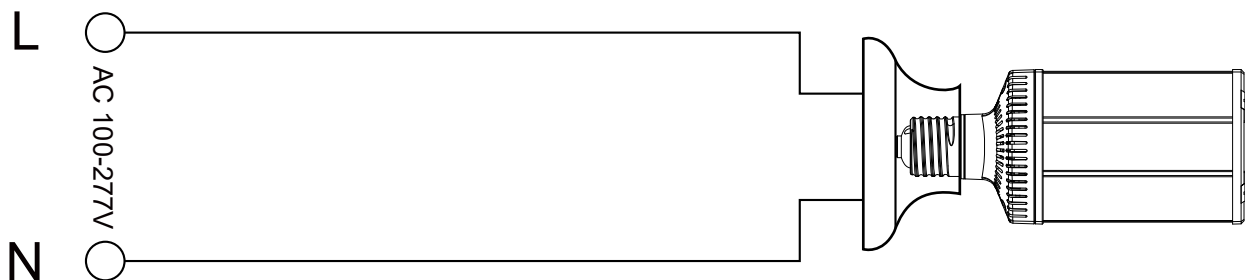

Flood Light Fixture



Cobra Fixture



Post Top Fixture



Shoobox Fixture



Wall Pack Fixture



High Bay Fixture



LED corn light can be widely used in warehouse, workshop, parking lot, street lighting, with high bay, shoebox, canopy fixtures.



Parking Lot



Yard



Street



Stadium

PACKAGE

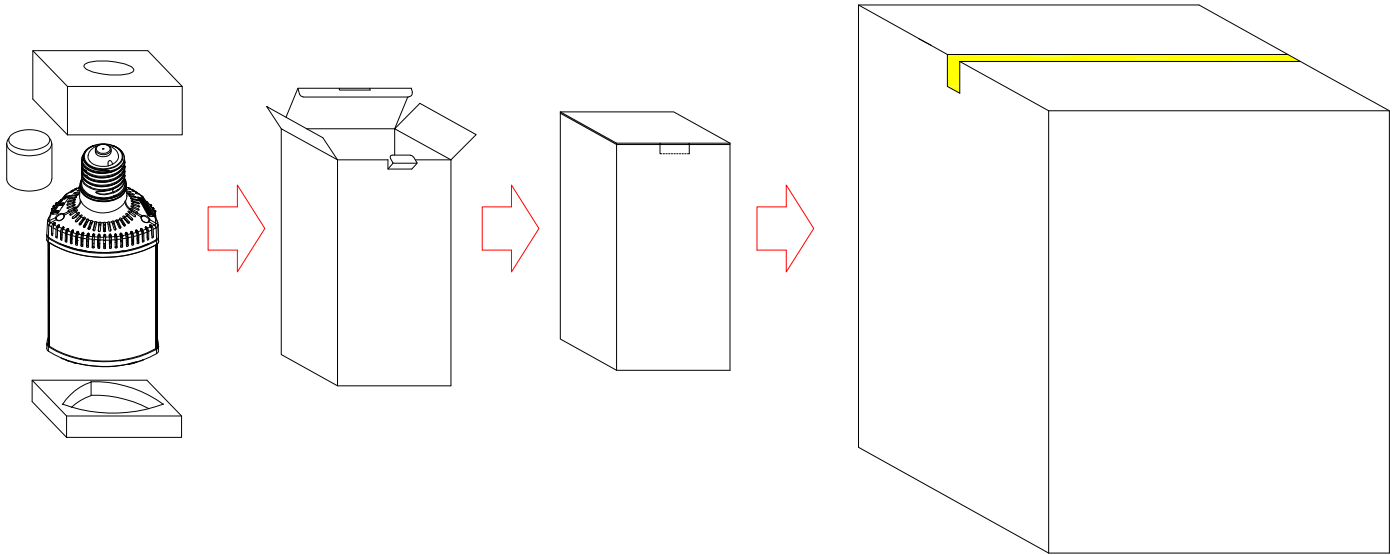

| Series | Unit | Package Size | Gross Weight | Volume |
|-----------------------|--------|-------------------------------------|--------------------|---------------------|
| HCL-60W HCL-60WH | 1 PC | 133x112x220mm/ 5.24**4.41**8.66" | 0.60 kg/ 1.32 lbs | 0.003m ³ |
| HCL-80W HCL-80WH | 24 PCS | 485x420x460mm/ 19.09**16.54**18.11" | 15.5 kg/ 34.17 lbs | 0.093m ³ |
| HCL-100W HCL-100WH | 1 PC | 133x112x260mm/ 5.24**4.41**10.24" | 0.85 kg/ 1.89 lbs | 0.004m ³ |
| HCL-120W HCL-120WH | 16 PCS | 560x485x275mm/ 22.05**19.09**10.83" | 14.5 kg/ 31.96 lbs | 0.075m ³ |