

SPECIFICATION

LED Panel Light

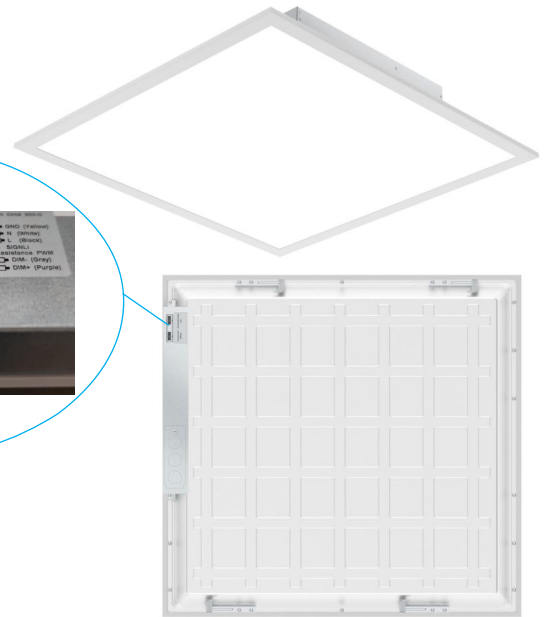

Maximum overall	A	B	C
2*2ft	603mm	603mm	35mm
1*4ft	1213mm	303mm	35mm
2*4ft	1213mm	603mm	35mm

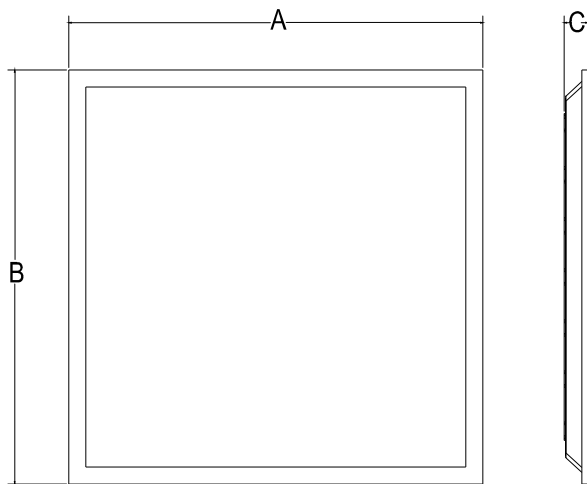

FEATURES

Input voltage: AC100-277V

Operating frequency: 50/60Hz

Power factor: > 0.95

Ambient temperature range: -20°C ~+35°C

Color Temp: 2700-5700K

Dimmable: 0-10V dimming

THD: ≤10%

IP Rating: IP20

CRI: >Ra80

Beam angle: 120°

- Luminous Flux:>130lm/w
- 5 years' warranty
- ETL & DLC Premium

PARAMETER

Length	Product code	Certification	CRI	Description		Function	Lumens 3000-6500K	Packing/carton
				Wattage	CCT Tunable			
2*2FT	NG-FPN-40W	ETL/cETLus,DLC	>80	20/25/30/35/40W	2700/3500/4000/5000/5700K	0-10V dimming CCT Tunable & Power adjustable	2600-5200LM	650*230*650mm 6 pieces 1*40HQ Loading=4320pcs
1*4FT	NG-FPN-40W	ETL/cETLus,	>80	20/25/30/35/40W	2700/3500/4000/5000/5700K	0-10V dimming CCT Tunable & Power adjustable	2600-5200LM	1260*230*350mm 6 pieces 1*40HQ Loading=3942pcs
2*4FT	NG-FPN-72W	ETL/cETLus,DLC	>80	30/40/50/60/72W	2700/3500/4000/5000/5700K	0-10V dimming CCT Tunable & Power adjustable	3900-9360LM	1260*230*650mm 6 pieces 1*40HQ Loading=2220pcs

MOUNTING GUIDES

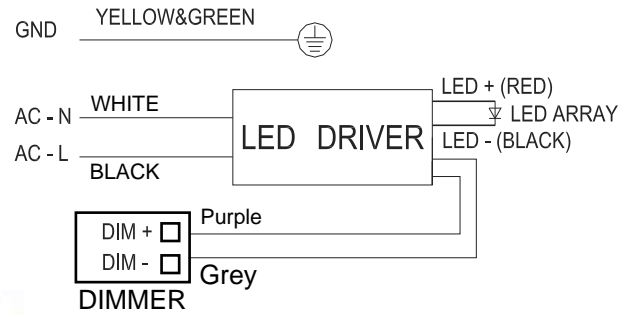
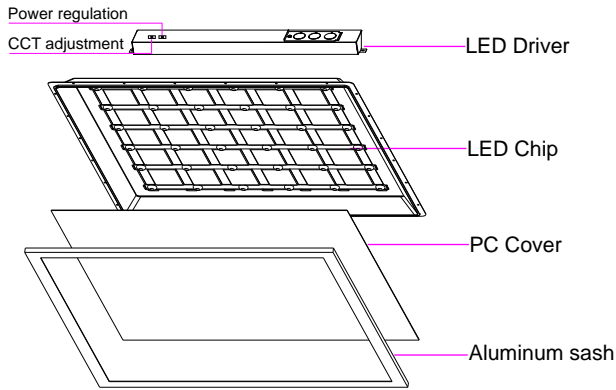

Electric Shock Attention

Ensure the power supply has been cut off before connecting the wire, and all wiring and installation of this product are required to be operated by professionals.

INSTALLATION INSTRUCTION

Step1

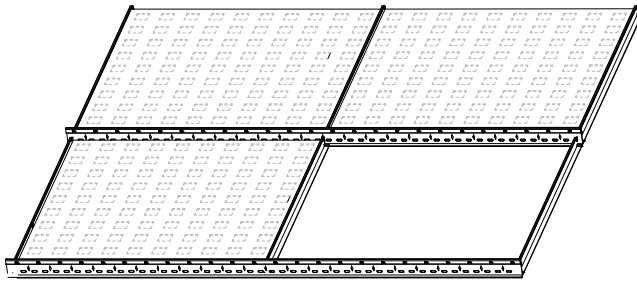

Step2

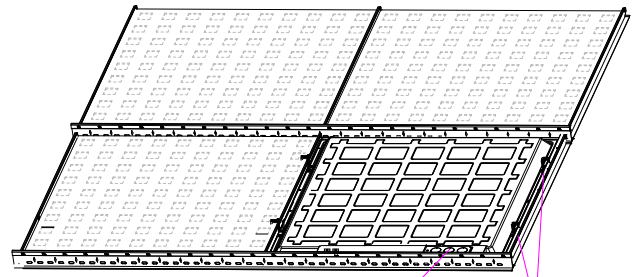

Step1-1

Step1-2

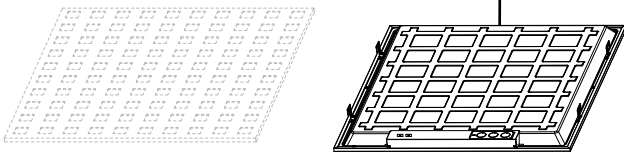

Step2-2

Step2-1

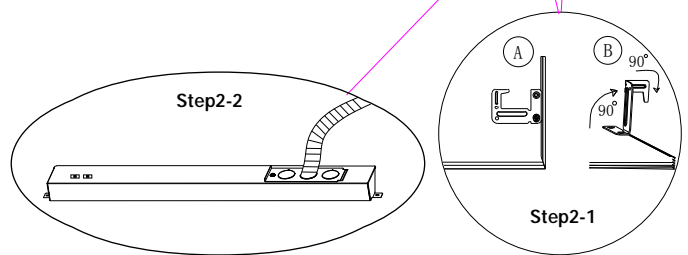

Step 1: Make sure of all the power is off before installing. Remove the one ceiling tile that you need to install light fixture on. Then place the light fixture on the T-bar carefully and make sure it is correctly in place and secure.

Step 2: Lift the 4 buckles on the back of the panel up by 90° then bend the top part of the buckles 90° towards the direction where you can anchor the light fixture to the T-bar.

Step 3: Place the driver on top of the lighting fixture in the back. Connect the cable between the driver and the lighting fixture. Open the driver's junction box and connect the AC wire to the driver correctly (L=black & N=white)

Warning:

1. Please read the instructions carefully before installation.
2. Please make sure the power is off before installation.
3. The installation can only be done by certified electricians.
4. Product rated voltage is 100-277 Volts. Please make sure voltage range meets the requirements
5. please don't use chemicals to clean the lighting surface.